



MOBILITY SCOOTER USER MANUAL



Congratulations on the purchase of your new Liberty Mobility Scooter! The advanced light-weight design of the Liberty with its superb leg room and streamline design ensures many years of enhanced trouble-free mobility. Correct use improves your mobility and quality of life.

Your safety is important to us.

Please read this owner’s manual before using the scooter. Improper use of the scooter could result in harm, injury or traffic accidents. Correct use improves your mobility and quality of life. This owner’s manual includes operation instructions for every aspect of the scooter.

CONTENTS

1.0	SAFETY GUIDELINES	2
2.0	PRE RIDE SAFETY CHECK	3
3.0	SPECIFICATION	4
4.0	COMPONENTS OF THE SCOOTER	5
5.0	OPERATION – CONTROL PANEL	6-7
6.0	OPERATION – SCOOTER ASSEMBLY.....	7-11
7.0	OPERATION – SCOOTER DISASSEMBLY	12-13
8.0	OPERATION – GETTING ON YOUR SCOOTER.....	13-14
9.0	OPERATION – OPERATING YOUR SCOOTER	15-16
10.0	OPERATION – GETTING OFF YOUR SCOOTER.....	17
11.0	OPERATION – BATTERIES AND CHARGING	17-19
12.0	EMI	20
13.0	DAILY CHECKING	21
14.0	MAINTENCE	21
15.0	BASIC TROUBLESHOOTING	22
16.0	FLASH CODES	23
17.0	WARRANTY	24-25

1.0 SAFETY GUIDELINES



WARNING! An authorized Provider or qualified technician must perform the initial setup of this scooter and must perform all of the procedures in this manual.

The symbols below are used throughout this owner's manual and on the scooter to identify warnings and important information. It is very important for you to read them and understand them completely.



WARNING! Indicates a hazardous situation that could result in serious injury or death if it is not avoided.



CAUTION! Indicates a hazardous situation that could result in minor or slight injury if it is not avoided.



IMPORTANT! Indicates a hazardous situation that could result in damage to property if it is not avoided.



Gives useful tips, recommendations and information for efficient, trouble-free use.

Your scooter is a state-of-the-art life-enhancement device designed to increase mobility. We provide an extensive variety of products to best fit the individual needs of the scooter user. Please be aware that the final selection and purchasing decision regarding the type of scooter to be used is the responsibility of the scooter user who is capable of making such a decision and his/her health care professional (i.e., medical doctor, physical therapist, etc.).

The contents of this manual are based on the expectation that a mobility device expert has properly fitted the scooter to the user and has assisted the prescribing health care professional and/or the authorized provider in the instruction process for the use of the product.

There are certain situations, including some medical conditions, where the scooter user will need to practice operating the scooter in the presence of a trained attendant. A trained attendant can be defined as a family member or care professional specially trained in assisting a scooter user in various daily living activities.

As you begin using your scooter during daily activities you will probably encounter situations in which you will need some practice. Simply take your time and you will soon be in full and confident control as you manoeuvre through doorways, on and off elevators, up and down ramps, and over moderate terrain.

Additional general information can be found on the supplemental information sheets and booklets included in your Owner's Package. Please fully read and review the information, and keep it readily available for future reference.

2.0 PRE-RIDE SAFETY CHECK

Get to know the feel of your scooter and its capabilities. We recommend that you perform a safety check before each use to make sure your scooter operates smoothly and safely.

Perform the following inspections prior to using your Travel Scooter:

- Check the condition of the tyres. Make sure they are not damaged or excessively worn.
- Check all electrical connections. Make sure they are tight and not corroded.
- Check all harness connections. Make sure they are secured properly.
- Check the battery condition meter to ensure the batteries are fully charged.
- Ensure the manual freewheel lever is in drive mode before sitting on the Travel Scooter.

If you discover a problem, contact your authorized Provider for assistance. Please refer to the Contact Information insert in your Owner's Package.



WARNING! Never exceed the maximum permissible load – see 3.0 Specifications and never use the scooter to transport more than one person.



WARNING! Never drive the scooter under the influence of medication or alcohol.



WARNING! Never attempt to get onto or off your scooter without first removing the key from the key switch. This will prevent the scooter from moving if accidental throttle control lever contact is made.



WARNING! Never drive the scooter with tiller lock in the locked position.

3.0 SPECIFICATION

Model Reference	Liberty 12Ah	Liberty Super 20Ah
Speed (Max)	4 mph (6 km/h)	4 mph (6 km/h)
Travel Range (Max)*	10 mi. (16 km)*	16 mi. (25 km)*
Battery	2 x 12V 12Ah AGM	2 x 12V 20Ah AGM
User Weight (Max)	21 st. (135kg)	21 st. (135kg)
Heaviest Part When Disassembled	14 kg	14 kg
Total Weight W/O Batteries	33 kg	33 kg
Total Weight With Batteries	42 kg	47 kg
Overall Length	1035 mm (41 in.)	1035 mm (41 in.)
Overall Width	490 mm (19 in.)	490 mm (19 in.)
Overall Height	920 mm (36 in.)	920 mm (36 in.)
Climbing Gradient (Max)	10 Degrees	10 Degrees
Turning Radius (Min)	1370 mm (54 in.)	1370 mm (54 in.)
Ground Clearance (Max Mid Frame)	55 mm (2 in.)	55 mm (2 in.)
Seat Type	Standard	Standard
Seat Width	460 mm (18 in.)	460 mm (18 in.)
Seat Height	400-480 mm	400-480 mm
Front Tyre	190 mm (7.5 in.) Solid Puncture Proof	190 mm (7.5 in.) Solid Puncture Proof
Rear Tyre	190 mm (7.5 in.) Solid Puncture Proof	190 mm (7.5 in.) Solid Puncture Proof
Basket	Black Metal	Black Metal
Tiller Lock	Yes	Yes
Tiller Type	Delta Handle	Delta Handle
Charger	2 Amp	2 Amp
Charging Type	Battery Box	Battery Box
Motor	180W	180W
Brake	Automatic Electromagnetic	Automatic Electromagnetic

REMARK: One Rehab reserves the right to modify the specification if necessary. The final specification is subject to the individual scooter you purchase from your dealer.

*Subject to user weight and terrain

4.0 COMPONENTS OF THE SCOOTER



- | | |
|---------------------------------|---------------------------------|
| 1. Control Panel | 12. Freewheel Lever |
| 2. Seat Arm Pad | 13. Seat Post Retaining Screw |
| 3. Seat | 14. Splitting Pin/Knob |
| 4. Basket | 15. Anti-Tip Wheel |
| 5. Tiller Adjuster Knob | 16. Rear Wheel |
| 6. Tiler Lock | 17. Battery Gauge |
| 7. Seat Post | 18. Speed Adjustment Dial |
| 8. Front Wheel | 19. Key Switch |
| 9. Battery Charger Outlet Point | 20. Tiller Handle |
| 10. Battery Box | 21. Horn Button |
| 11. Arm Rest Retaining Screw | 22. Throttle Lever Forward/Back |

Your scooter is equipped with a number of elements and parts. You should know these before using the scooter. Designs and specifications may change without prior notice.

5.0 CONTROL PANEL

- | | |
|-----------------------------|---------------------------------|
| 17. Battery Indicator/Gauge | 20. Tiller Handle |
| 18. Speed Adjustment Dial | 21. Horn Button |
| 19. Key Switch | 22. Throttle Lever Forward/Back |



5.1 Battery Indicator/Gauge: (17)

Indicates the voltage of the batteries:

- Green – batteries are fully charged.
- Yellow – batteries are half full.
- Red – batteries need charging.
- Beeping sound continuing – batteries are out of charge. Please re charge batteries.

5.2 Speed Adjustment Dial: (18)

This dial allows you to preselect and limit your Scooter's top speed in the range of 0mph – 4mph:

- The image of the snail represents the slowest speed setting.
- The image of the hare represents the fastest speed setting.

5.3 Key Switch: (19)

This turns the power on and off your scooter.

- Insert the key into the key switch.
- Turn the key clockwise to turn on your scooters power. The battery indicator will light up to indicate that the power is on.
- Turn the key anti-clockwise to turn off your scooter's power. The battery indicator light will turn off to indicate the power is off.

5.4 Horn Button: (21)

This button activates a warning horn. Your scooter must be turned on for the horn to be operational. Do not hesitate to use the warning horn when doing so may prevent an accident or injury.

5.5 Throttle Control Lever – Forward/Back: (22)

This lever allows you to control the forward speed and the reverse speed of your scooter up to the maximum speed you pre-set with the speed adjustment dial.

Place your right hand on the right hand tiller handle and your left hand on the left hand tiller handle:

To move forward, use either of the following:

- Use your left thumb to push the left side of the throttle control lever.
- Use your right hand fingers to pull back on the right side of the throttle control lever.

To move backward, use either of the following:

- Use your right thumb to push the right side of the throttle control lever.
- Use your left hand fingers to pull back on the left side of the throttle control lever.

Release the lever and allow your scooter to come to a complete stop before pushing the other side of the lever to move in reverse. When the scooter is moving in reverse, the reverse beeper will sound. When the throttle is completely released, it automatically returns to the centre “stop” position and engages your scooter’s brakes.

6.0 ASSEMBLY OF YOUR SCOOTER

The scooter assembles from five main pieces: the basket, front section, rear section, seat and battery box as shown below:

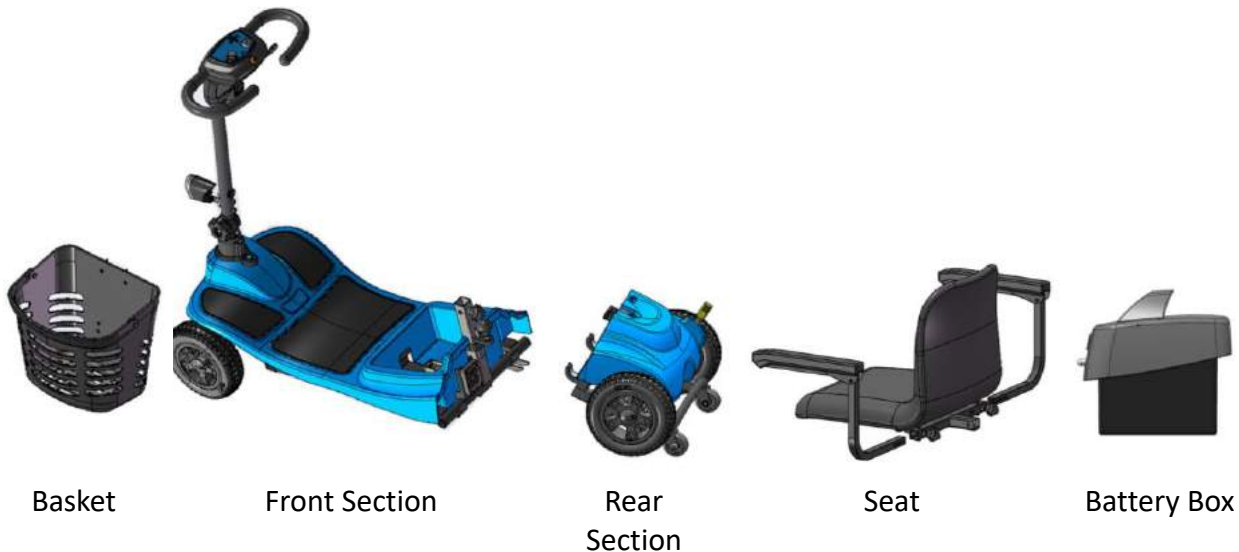

- When disassembling or assembling your scooter, always make sure you have sufficient room to move the parts around. You may need assistance to lift some of the scooter components.
- See “Specifications” for individual component weights.
- No tools are required to disassemble or assemble your scooter. Always disassemble or assemble your scooter on a level, dry surface with sufficient space for you to work and move around your scooter. Keep in mind that the disassembled sections of the scooter take up more floor space than the assembled scooter.



CAUTION! Lifting weight beyond your physical capability may result in personal injury.

Ask for assistance when necessary while disassembling or assembling your scooter.

6.1 TILLER ADJUSTMENT KNOB

- Loosen the tiller adjustment knob by turning anti-clockwise - see below.
- Raise the tiller to the required position.
- Fully tighten the adjustment knob by turning clockwise making sure the tiller is securely positioned with the teeth fully engaged together.



WARNING! Never operate the scooter unless the tiller is raised, the teeth are fully engaged and the tiller adjustment bolt fully tightened and securely positioned.

6.2 TILLER LOCK

- The scooter has been provided with a tiller lock which makes transporting and carrying the scooter easier. It is only to be used when the scooter is dismantled, either for transportation or storage.
- To unlock - fully press the tiller lock button down then quickly release your finger. The button will spring up to the unlocked position. The tiller will now move sideways.
- To lock – set the wheels to be directly facing forward, press the tiller lock button down firmly and release your finger. The button will stay down in the locked position.

Tiller Lock in un-locked position:



Tiller Lock in locked position:



WARNING! Never drive the scooter with tiller lock in the locked position.

6.3 CONNECTING FRONT & REAR SECTIONS

- Connect the front and rear sections by aligning them and gently lifting the front section onto the two hooks of the rear section. (See Fig 6.3.1) Make sure the rear section is tipping back to allow the front section to lower into the correct position.
- Make sure the front and rear sections are securely and correctly connected. (See Fig 6.3.2)



CAUTION! When assembling the front and rear sections together keep fingers well clear of 'pinch points'.

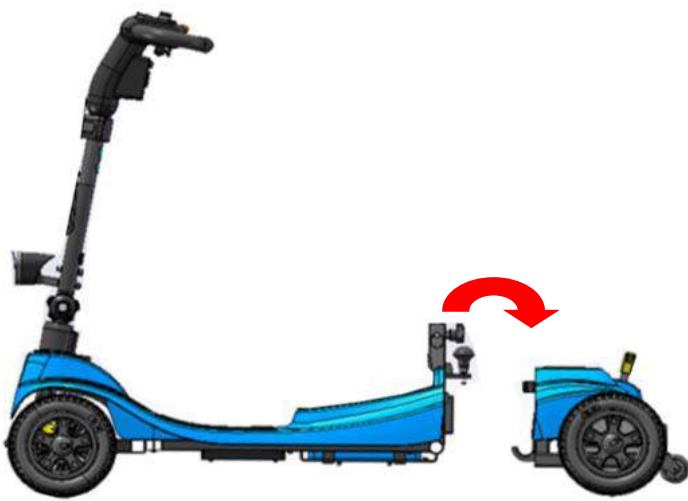

Fig 6.3.1



Fig 6.3.2

6.4 SEAT POST

- Adjust seat post to your require height by using the seat post pin provided. Then securely tighten seat post retaining screw. (See Fig 6.4.1)



Fig 6.4.1

6.5 FITTING BATTERY BOX AND BASKET

- Carefully lower the battery box into position on the scooter making sure the box is securely and fully connected to the battery connector. (See Fig 6.5.1)
- Place basket onto bracket and make sure it is securely fixed. (See Fig 6.5.1)



Fig 6.5.1

6.6 FITTING SEAT

- Stand behind the scooter and with both hands lower the seat onto the seat post making sure the seat is straight above the seat post. (See Fig 6.6.1) If the seat is not straight on the seat post you will not be able to fully lock the seat. Make sure seat has fully locked onto seat post.
- Fix arm rests and adjust to the required width, then tighten arm rest retaining screws securely. (See Fig 6.6.2)



Fig 6.6.1



Fig 6.6.2



CAUTION! Make sure the seat is fully locked onto the seat post before sitting.

6.7 FREEWHEEL LEVER

- The Freewheel lever on the scooter is located on the rear section of the scooter. Before driving the scooter needs to be put into the drive position. The two positions are:

1. Drive position - is indicated by 'Closed' - pull the lever backwards for this position. (Fig 6.7.1)

2. Freewheel position - is indicated by 'Open' – push the lever forwards for this position. (Fig 6.7.2)



Fig 6.7.1 Drive Mode (Closed)

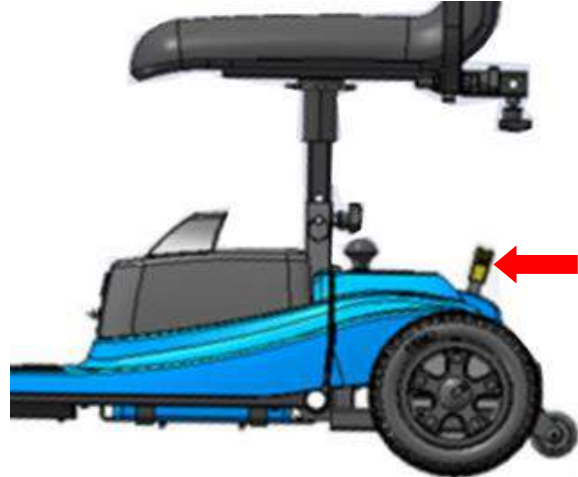

Fig 6.7.2 Freewheel Mode (Open)



WARNING! Before placing your scooter into or taking it out of freewheel mode, remove the key from the key switch. Never sit on the scooter when it is in freewheel mode. Never put your scooter in freewheel mode on any incline.



WARNING! When your scooter is in freewheel mode, the braking system is disengaged.



WARNING! Disengage the drive motors only on a level surface.



WARNING! Ensure the key is removed from the key switch.



WARNING! Stand to the side of the scooter to engage or disengage freewheel mode. Never sit on a scooter to do this.



WARNING! After you have finished pushing your scooter, always return it to the drive mode to lock the brakes.

7.0 DISASSEMBLY OF YOUR SCOOTER

The scooter disassembles into five main pieces: the basket, front section, rear section, seat and battery box as shown below:

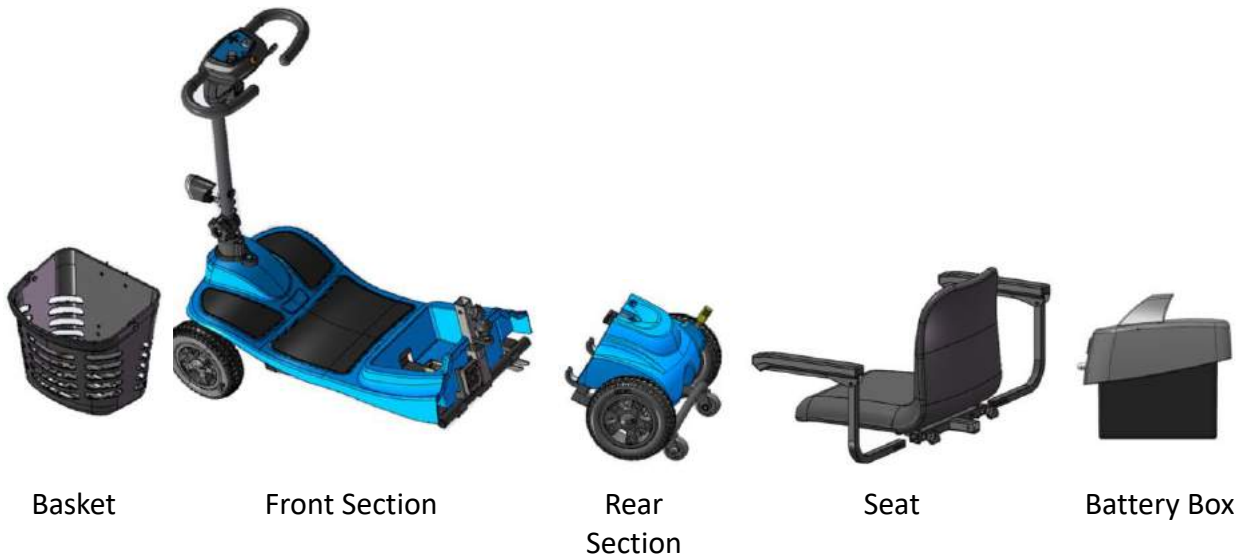

- When disassembling or assembling your scooter, always make sure you have sufficient room to move the parts around. You may need assistance to lift some of the scooter components.
- See “Specifications” for individual component weights.
- No tools are required to disassemble or assemble your scooter. Always disassemble or assemble your scooter on a level, dry surface with sufficient space for you to work and move around your scooter. Keep in mind that the disassembled sections of the scooter take up more floor space than the assembled scooter.



CAUTION! Lifting weight beyond your physical capability may result in personal injury. Ask for assistance when necessary while disassembling or assembling your scooter.

- 7.1 REMOVE THE SEAT** - Stand behind the scooter and fold the seat back down, then with both hands lift seat directly upwards.
- 7.2 REMOVE THE BATTERY BOX** - Grip the battery box handle firmly and lift directly upwards and off the scooter.
- 7.3 REMOVE THE BASKET** – Stand in front of the scooter and lift basket directly upwards off the basket bracket.
- 7.4 FOLD DOWN THE TILLER**
- Loosen the tiller adjustment knob by turning anti-clockwise.
 - Carefully lower the tiller.
 - With the tiller in its lowered position, tighten the adjustment knob by turning clockwise making sure the tiller is securely positioned – see Assembly 6.1
 - Lock the tiller lock – see Assembly 6.2

7.5 DISCONNECTING FRONT & REAR SECTIONS

- Lift the tiller splitter knob. (See Fig 7.5.1) The front and rear sections will then be disconnected.

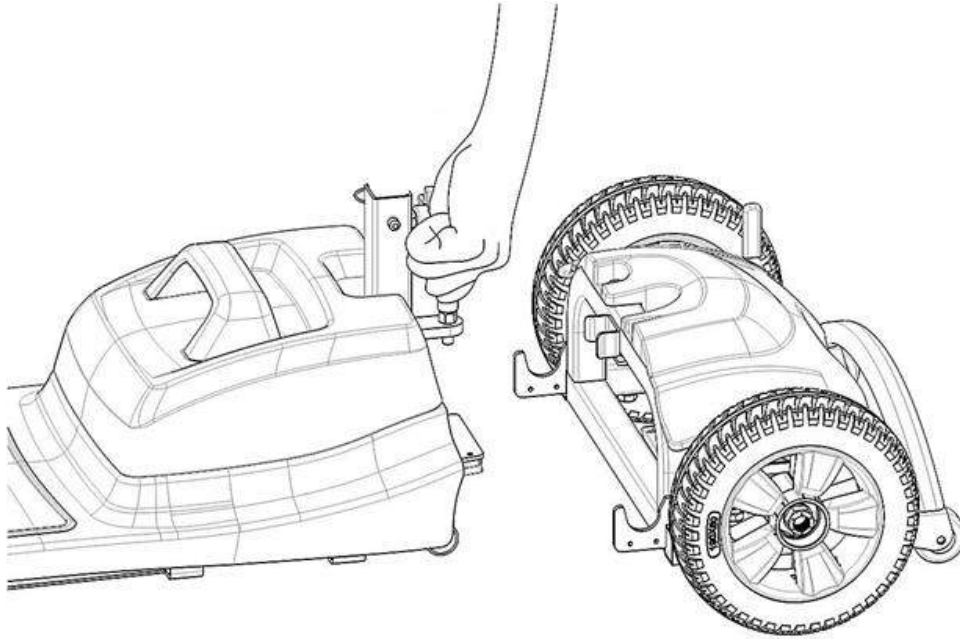

Fig 7.5.1

8.0 BEFORE GETTING ON TO YOUR SCOOTER

- Keep your batteries fully charged and avoid deeply discharging your batteries.
- Never leave the manual freewheel lever in the forward position unless you are manually pushing your scooter.



WARNING! Never attempt to get onto or off of your scooter without first removing the key from the key switch. This will prevent the scooter from moving if accidental throttle control lever contact is made.



WARNING! Never sit on the scooter when it is in freewheel mode.



WARNING! Never exceed the maximum permissible load – see 3.0 Specifications and never use the scooter to transport more than one person.



WARNING! Never drive the scooter under the influence of medication or alcohol.



WARNING! Never drive the scooter with tiller lock in the locked position.

8.1 GETTING ONTO YOUR SCOOTER

1. Make certain that the key is removed from the key switch.
2. Make sure the tiller is in the un-locked position.
3. Stand at the side of your scooter.
4. Disengage the seat rotation lever and rotate the seat until it is facing you.
5. Make certain that the seat is secured into position.
6. Position yourself comfortably and securely in the seat.
7. Disengage the seat rotation lever and rotate the seat until you are facing forward.
8. Make certain that the seat is secured into position.
9. Make certain that your feet are safely on the floorboard.



WARNING! The following can adversely affect steering and stability while operating your scooter:

- Holding onto or attaching a leash to walk your pet.
- Carrying passengers (including pets).
- Hanging any article from the tiller.
- Towing or being pushed by another motorized vehicle.

! IMPORTANT! Keep both hands on the tiller and your feet on the floorboard at all times while operating your scooter. This driving position gives you the most control over your vehicle.

9.0 OPERATING YOUR SCOOTER

9.1 STARTING

- Make sure you are seated safely and properly on your scooter.
- Turn the speed adjustment dial fully anti-clockwise to the slowest setting.
- Insert the key into the key switch.
- Turn the key clockwise to the “On” position.
- Place your hands on the handgrips:
 - Pull on the left hand grip to steer your scooter to the left.
 - Pull on the right hand grip to steer your scooter to the right.
- Move the tiller to the centre position to drive straight ahead.
- Slowly engage the throttle control lever to gently accelerate your scooter forwards by either:
 - Use your left thumb to push the left side of the throttle control lever forward.
 - Use your right hand fingers to pull back on the right side of the throttle control lever.
- To stop release the throttle control lever to allow your scooter to stop gradually. The electronic brakes will automatically engage when your scooter comes to a stop.

9.2 STEERING

- Place both hands on the handgrips of the tiller, turn the tiller to the right to travel right – never turn at high speeds as this will result in loss of control.
- Turn the tiller to the left to turn left – never turn at high speeds as this will result in loss of control.
- Make sure to maintain sufficient clearance when turning your scooter so that the rear wheels will be clear of any obstacles.
- Show even greater caution when steering in reverse.



WARNING! Turning your scooter too sharply at high speed will cause loss of control and balance and will result in the scooter tipping over resulting in serious injury or death.

9.3 DRIVING ON INCLINES, HILLS, SLOPES AND RAMPS

- When driving your scooter, never descend or climb a gradient which is greater than recommended – see 3.0 Specifications. Failure to do so could result in serious injury or death.
- When driving up a ramp, curb or incline - lean forward to move the centre of gravity of the scooter forward for maximum stability and safety.
- Drive with extreme caution when attempting to drive up or down any incline, access ramp etc, always drive at a slow speed.
- Always drive straight up or straight down an incline, ramp, slope etc.
- Never drive across (traverse) an incline, ramp etc, in any direction – Driving across an incline, ramp etc could result in turning the scooter over resulting in serious injury or death.
- Try to keep your scooter moving when climbing or descending an incline. If you have to stop, restart and accelerate slowly and carefully.



WARNING! Never descend or climb a gradient which is greater than the recommended maximum see 3.0 Specifications.



WARNING! Never drive across (traverse) an incline, ramp etc, in any direction.



WARNINIG! The anti-tip wheels are only effective on firm ground. They will sink into soft ground such as grass, snow or mud if the scooter rests on them. They will lose their effect and the scooter can tip over.



WARNING! While you are driving down a slope, if your scooter starts to move faster than you feel safe, release the throttle control lever slowly. It will allow your scooter to decelerate and slow down.

9.4 DROP CURBS

- Always be cautious when descending a drop curb.
- Approach the curb so that both back wheels of your scooter go over the curb at the same time.
- Never go down curbs by traversing them. Doing this will cause the scooter to tip over resulting in serious injury or death.
- Drive down curbs slowly to avoid jarring bumps.

9.5 GRASS AND GRAVEL

- Your scooter performs well on short firm grass and hills but you must follow the operational parameters presented in this manual. If you are unsure about any situation, avoid it.
- Avoid driving in long grass, this will result in grass wrapping around you scooters axle and potential damage to the scooter.
- Avoid driving on loose gravel, this will result in loss of control of the scooter.



WARNINIG! The anti-tip wheels are only effective on firm ground. They will sink into soft ground such as grass, snow or mud if the scooter rests on them. They will lose their effect and the scooter can tip over.

10.0 GETTING OFF YOUR SCOOTER

1. Bring your scooter to a complete stop.
2. Remove the key from the key switch.
3. Disengage the seat rotation lever and rotate the seat until you are facing toward the side of your scooter.
4. Make certain that the seat is secured into position.
5. Carefully and safely get out of the seat and stand to the side of your scooter.
6. You can leave the seat facing to the side to facilitate boarding your scooter next time.



WARNING! Never attempt to get onto or off of your scooter without first removing the key from the key switch. This will prevent the scooter from moving if accidental throttle control lever contact is made.

11.0 BATTERIES AND CHARGING

11.1 GENERAL INFORMATION & INSTRUCTIONS ON CHARGING

Your Scooter requires 2 x lead acid batteries that are sealed and maintenance free. They are recharged by the supplied off-board charging system.

- Fully charge your travel scooter's batteries for at least 10 to 12 hours prior to using it for the first time. New batteries will be at their full capacity after having run through approx. 10-20 charging cycles (break-in period). This break-in period is necessary to fully activate the battery for maximum performance and longevity.
- Keep the batteries fully charged to keep your scooter running smoothly. Charge the batteries daily after every discharge even after partly discharge. Depending on the level of discharge, it can take up to 12 hours until the batteries are fully charged again.
- If the battery indicator has reached the red LED range, charge the batteries for 16 hours minimum, ignoring the charge complete display!
- Even if the scooter is unused for long period of time, the batteries should have a 24 hour charge once a week to make sure that both batteries are fully charged.
- Do not cycle your batteries at a low state of charge without regularly recharging them fully.
- Do not charge your batteries under extreme temperatures. High temperatures above 30°C are not recommended for charging as well as low temperatures below 10°C.
- You cannot overcharge the batteries when using the charger supplied with your vehicle, or a charger that has been approved by One Rehab.
- Protect your charger from sources of heat such as heaters and direct sunlight. If the battery charger overheats, charging current will be reduced and the charging process delayed.

11.2 CHARGING YOUR BATTERIES

- Make sure you read and understand the battery chargers user manual, if supplied, as well as the safety notes on the charger.
- Turn off the scooter power and remove the key
- Slide away the cover of the charger outlet point positioned on the front of the battery box as shown below:



- Put the charger plug into the outlet point
- Do not switch on the battery charger until all the plugs are in position
- The LED light on the battery charger will show amber while charging
- The LED light on the battery charger will show green when batteries are fully charged
- Turn off the mains power to the charger before removing the charger plug from charging outlet



WARNING! Risk of explosion and electric shock if batteries are charged when incorrectly wired. Never attempt to open or disassemble the battery box. If the batteries do not appear to be working correctly, contact your authorized provider.



WARNING! Risk of explosion and destruction of batteries if the wrong battery charger is used. Only ever use the battery charger supplied with your vehicle, or a charger that has been approved by One Rehab. Never charge 12 Ah batteries with a 5 Ah battery charger. Always use a 2 Ah battery charger.



WARNING! Never attempt to open or disassemble the charger. If the battery charger does not appear to be working correctly, contact your authorized provider.



WARNING! Risk of electric shock and damage to the battery charger if it gets wet. Always protect the battery charger from water and always charge in a dry environment.



WARNING! Risk of short circuit and electric shock if the battery charger has been damaged. Never use the charger if it has been dropped or damaged.



WARNING! Risk of electric shock and damage to the batteries – Never attempt to recharge the batteries by attaching cables directly to the battery terminals.



WARNING! Risk of fire and electric shock if a damaged extension cable is used. Only ever use an extension cable if it is absolutely necessary. If you have to use an extension cable make sure it is in good condition.



WARNING! Risk of injury if using the scooter during charging. Do not attempt to recharge the batteries and operate the scooter at the same time. Do not sit in the scooter while charging the batteries.



WARNING! Chargers are selected precisely for particular applications and are especially matched to the type, size, and chemical formulation of specific batteries. For the safest and most efficient charging of your scooter's batteries, we recommend use of the charger supplied as original equipment with your product only. Any charging method resulting in batteries being charged individually is especially prohibited.



WARNING! Never attempt to disassemble the battery from the battery box or refit the battery. Contact your authorized provider.



WARNING! If your battery charger has not been tested and approved for outdoor use, then do not expose it to adverse or extreme weather conditions. If the battery charger is exposed to adverse or extreme weather conditions, then it must be allowed to adjust to the difference in environmental conditions before use indoors. Refer to the manual supplied with the battery charger for more information.

12.0 EMI / RFI

The rapid development of electronics, especially in the area of communications, has saturated our environment with electromagnetic (radio) waves that are emitted by television transmitters, cellular phones, citizen's band radios (CB's), amateur radios (ham radios), wireless computer left, microwave transmitters, paging transmitters etc. These electromagnetic (EM) waves are invisible and increase in strength the closer one gets to the source of transmission. When these energy waves act upon electrical devices and cause them to malfunction or to function in an erratic or uncontrolled manner, they are referred to as Electromagnetic Interference (EMI) or Radio Frequency Interference (RFI).

EMI / RFI and your scooter

All electrically powered vehicles, including scooters are susceptible to Electromagnetic Interference / Radio Frequency Interference (EMI / RFI). This interference could result in abnormal, unintended movement of your scooter.



WARNING! Unintended movement or brake release can cause an accident or injury

The FDA has determined that each make and model of scooter can resist EMI / RFI to a certain level. The higher the level of resistance, the greater the degree of protection from EMI / RFI – measured in volts per meter (V/m). The FDA has also determined that current technology is capable of providing 20 V/m of resistance to interference. This product has been tested and has passed an immunity level of 20 V/m.

EMI / RFI recommendations

- Do not turn on or use hand-held personal electronic communication devices such as cellular phones, walkie-talkies and CB radios while your scooter is turned on;
- Be aware of any nearby transmitters (radio, television, microwave, etc.) on your intended route and avoid operating your scooter close to any of those transmitters;
- Turn off the power if your scooter is going to be in a stationary position for any length of time;
- Be aware that adding accessories or components or modifying your scooter may make it more susceptible to EMI / RFI;



WARNING! Turn off your scooter as soon as it is safely possible if unintended or uncontrollable motion occurs or if unintended park brake release occurs.

13.0 DAILY CHECKING

Check the following items before driving. If you find anything abnormal, contact your scooter dealer for a further inspection before using it.

Item	Inspection Content
Handle bar	Is it tight? Can they be turned left or right smoothly?
Speed Dial	Can it be adjusted freely and function well?
Throttle Lever	Does the scooter move when the lever is engaged? Does the scooter stop when the lever is released completely?
Motor	Is there any abnormal noise from the motor? Does the electromagnetic brake work properly?
Battery Gauge	Does the gauge move to green when switched "ON"? Is the remaining power enough for your trip?
Horn Button	Does the horn work?
Seat	Is the seat on properly?

13.1 REGULAR CHECKING RECORD

To make sure your scooter is in good condition, go to your scooter dealer regularly.

13.2 CIRCUIT BREAKER

There is one button for the circuit breaker (located on the battery pack), if the power switch is "ON" and the battery gauge does not move, it is possible an electric current has overloaded the scooter. Reset the circuit breaker by pressing the button.

13.3 TYRES

The condition of the tyres depends on how you drive and use your scooter.

Inspecting Tyre Treads

Please check the tread depth regularly. Replace the tyres when the tread depth is less than 0.5 mm.

14.0 MAINTENANCE

1. Do not use water, oil or other chemical solutions to clean your scooter. Be sure NOT to spray the scooter with the water as this can damage the electronic components. Please clean the scooter by wiping it with either a dry or moist cloth.
2. Please take the scooter to authorized dealers for repairs and adjustments. Improper adjustments could lead to accidents and scooter malfunction.

15.0 BASIC TROUBLESHOOTING

This table is only a guide to aid you in getting your scooter operating, should you have any problems. If you are unable to get your scooter operating, please contact your Scooter Dealer.

Symptom	Possible	Solution
Scooter does not move	<ol style="list-style-type: none"> 1. Key switch is not "ON" 2. Main circuit breaker tripped 3. Brake release lever in 'Freewheel Mode' 4. Charger connected to outlet 5. Battery power low 6. Scooter shuts down to conserve battery 7. Controller error 	<ol style="list-style-type: none"> 1. Turn key switch to "ON" 2. Reset circuit breaker 3. Place lever in 'Drive Mode' 4. Disconnect charger 5. Recharge battery 6. Turn key switch "OFF", then "ON" 7. Check Power light for Flash Code (See 16.0 Flash Codes to get a solution))
Range less than expected	<ol style="list-style-type: none"> 1. Charging too infrequently 2. Defective or worn out battery 3. Cold weather reduces battery life 4. Defective charger 	<ol style="list-style-type: none"> 1. Charge scooter more often 2. Load test batteries. If necessary replace. 3. Allow batteries to reach room temperature and then fully recharge 4. Contact your Scooter Dealer

16.0 FLASH CODES

Scooter controller internal diagnostics

The diagnostic flash codes for your scooter are designed to help you perform basic troubleshooting quickly and easily. A diagnostic flash code flashes from the Power light in the event one of the conditions listed below develops.

FLASH CODE	FAULT	EFFECT ON THE SCOOTER	SOLUTION
1	Battery charge is too low or there is a bad connection.	Scooter continues to drive.	<ul style="list-style-type: none"> • Charge batteries. • Check all battery wiring connections. • Contact your service agent.
2	Bad connection to motor.	Scooter stops driving.	<ul style="list-style-type: none"> • Check all connections between the motor and controller. This includes the splitter connections between front and rear chassis. • Motor may be faulty and need replacing. • Contact your service agent.
3	Wiring short circuit.	Scooter stops driving.	<ul style="list-style-type: none"> • This is due to wiring damage and all wiring needs checking. • Contact your service agent.
4	Brake error.	Scooter stops driving.	<ul style="list-style-type: none"> • Ensure the manual freewheel lever is in the drive position and restart the scooter. • There is a fault with the magnetic brake or wiring. • Contact your service agent.
5	Controller circuit protection.	Scooter stops driving.	<ul style="list-style-type: none"> • The motor or its wiring is faulty causing too much current tripping controller. • Contact your service agent.
6	Throttle control lever not at centre position when switching on scooter.	Scooter stops driving.	<ul style="list-style-type: none"> • Put the throttle control lever in the central position, turn the power off and then turn on again. • Check that the charger is not connected.
7	Throttle Pot error.	Scooter stops driving.	<ul style="list-style-type: none"> • The Throttle Pot or its wiring could be faulty. • The Speed Pot or its wiring could be faulty. • Contact your service agent.
8	Controller error.	Scooter stops driving.	<ul style="list-style-type: none"> • Check all wiring connections including main battery connections. • The controller needs replacing. • Contact your service agent.
9	Brake error.	Scooter stops driving.	<ul style="list-style-type: none"> • Ensure the manual freewheel lever is in the drive position and restart the scooter. • The electronic brake has a bad connection or fault. Check the brake and motor connections including the splitter connections between front and rear chassis. • Also check the controller connections. • Contact your service agent.
10	Controller error.	Scooter stops driving.	<ul style="list-style-type: none"> • An excessive voltage has been applied to the controller. Often this is caused by a poor battery connection. Check the battery connections. • Contact your service agent.

17.0 WARRANTY

WARRANTY POLICY:

LIMITED WARRANTY. IMPORTANT NOTICE – TO ENSURE THIS WARRANTY IS VALIDATED IT HAS TO BE COMPLETED AND RETURNED TO ONE REHAB WITHIN 14 DAYS OF PURCHASE

17.1 TWO-YEAR LIMITED WARRANTY

Two years on all structural frame components; fork, seat post, and frame.

Structural Frame Components, including

1. Main Frame
2. Fork
3. Seat Post
4. Tiller Frame

17.2 ONE-YEAR LIMITED WARRANTY:

For one (1) year from the date of delivery, we will replace at our discretion to the original purchaser, free of charge, any part or electronic component found upon examination by an authorized representative of One Rehab to be faulty.

1. Electronic controllers
2. Transaxle
3. Motor & Brake: (electronic function ONLY).
4. Charger
5. Any other electrical subassembly

NOTE: If there is an increase in the noise level from the transaxle, the warranty does not apply. An increase in operational noise level usually occurs due to excessive strain on the scooter.

17.3 BATTERIES

Batteries are covered by a six (6) month warranty from the original manufacture and a further six (6) month warranty at the discretion of One Rehab.

Note: Gradual deterioration in performance due to batteries being left in a discharged state, left in cold conditions for long periods of time or worn out through heavy use is not covered.

17.4 WARRANTY EXCLUSIONS

1. ABS plastic shrouds and footrest covers (wear items are not warranted).
3. Tyres and Anti-tip Wheels (wear items are not warranted).
4. Upholstery and seating (wear items are not warranted).
5. Motor Brushes.
6. Brake Pads (wear items are not warranted).
7. Fuses.
8. Repairs and/or modifications made to any part of the scooter without specific and prior consent from **One Rehab**.
9. Circumstances beyond the control of **One Rehab**.

Exclusions also include components with damage caused by:

1. Contamination (rain, etc).
2. Abuse, misuse, accident, or negligence.
3. Commercial use, or use other than normal.
4. Improper operation, maintenance, or storage.

NOTE: Gradual deterioration in performance because the battery has been left in a discharged state, left in cold conditions for an extended period of time, or worn out through heavy use is not covered by the warranty.

17.5 SERVICE CHECKS AND WARRANTY SERVICE

This warranty is extended only to the original purchaser. Your original receipt will be necessary as proof of purchase before any warranty performances are rendered.

This warranty only covers failures due to defects in materials or workmanship which occur during normal use and does not cover damage that occurs in shipment or failures which are caused by products not supplied by **One Rehab** or failures resulting from accident, misuse, abuse, neglect, mishandling, misapplication, alteration, modification, commercial use or by anyone other than an authorized dealer, or damage that is attributable to the acts of God.

The manufacturer reserves the right to alter without notice, any weights, measurements or other technical data shown in this manual. All figures, measurements and capacities shown in this manual are approximate and do not constitute specifications.

Important

This warranty is void if the original scooter serial number tag is removed or altered. To validate the warranty this form must be filled online (where applicable) or posted to One Rehab (Unit 1, Fernwood Estate, Shillinglee Road, Chiddingfold, GU8 4SX within 14 days of purchasing the scooter.

17.6 NOTICES TO CONSUMER

There are no other express warranties. To the extent permitted by law, any implied warranty (including a warranty of merchantability or fitness for a particular purpose) is limited to:

1. One (1) year from the day of original delivery
2. Repair or replacement of the defective part only.

THIS PAGE IS INTENTIONALLY BLANK

Liberty

